



---

# INSTRUCTION MANUAL

## ELECTRONIC SWITCH

### DPS40, SPS20

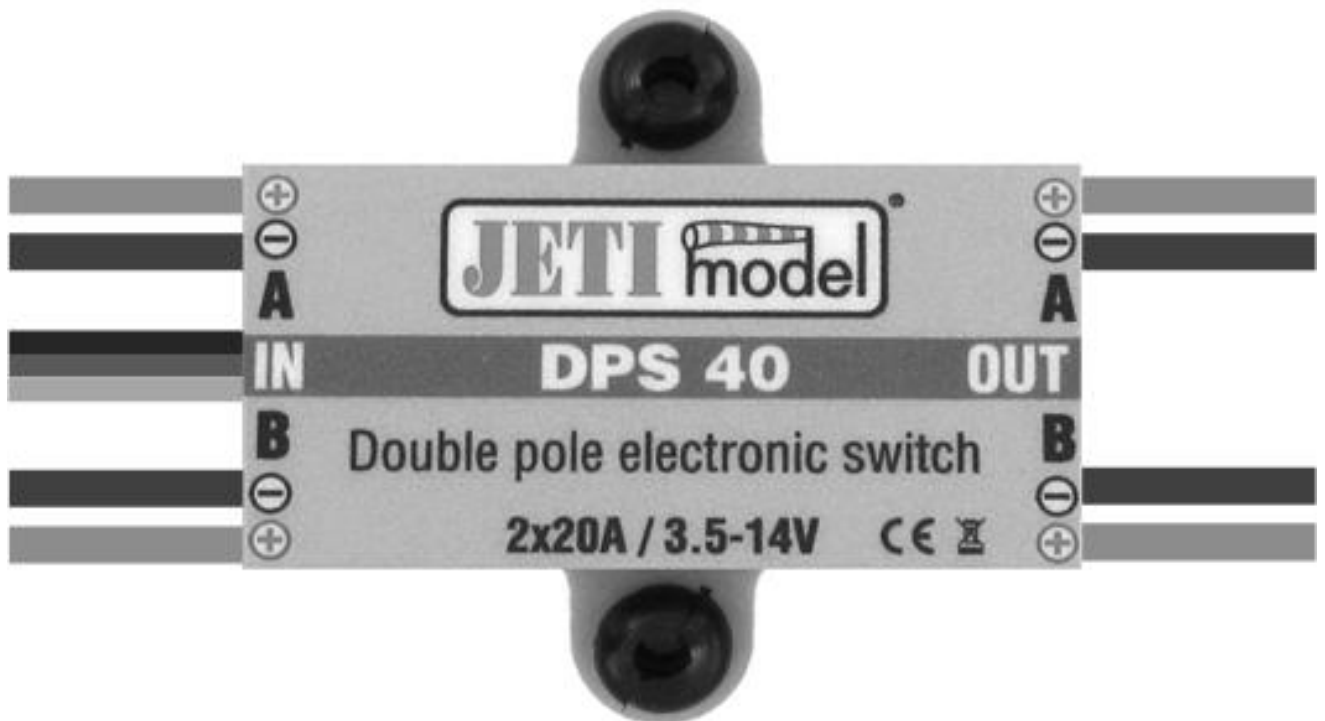

## **CONTENT**

<b>1. INTRODUCTION.....</b>	<b>3</b>
<b>2. WIRING OF THE ELECTRONIC SWITCH .....</b>	<b>3</b>
2.1 WIRING OF THE SPS20 .....	5
2.1 THE DPS40 WIRED AS TWO POLE SWITCH .....	5
2.2 THE DPS40 SWITCHED AS SINGLE POLE SWITCH.....	6
2.3 CHARGING OF THE BATTERY .....	7
<b>3. INSTALLATION .....</b>	<b>8</b>
<b>4. SAFETY BASICS FOR HANDLING MAGNETS.....</b>	<b>8</b>
<b>5. TECHNICAL DATA OF ELECTRONIC SWITCHES .....</b>	<b>8</b>
<b>6. WARRANTY.....</b>	<b>8</b>

## 1. Introduction

The DPS40 (twin electronic switch) and SPS20 (single electronic switch) are electronic switches mainly appointed to switching of supply voltages of receivers / servos, ESC, turbine pump or similar equipment. A big advantage of electronic switches in comparison to mechanical switches is in general their higher reliability as far as vibration resistance is concerned. Another advantage of the electronic switch is given by its practical ability to withstand an unlimited number of switching cycles. Electronic switches have no moving parts like contacts which would be wearing out during switching processes, therefore their longevity is extremely high. Moreover, they are not prone to spontaneous and unexpected false tripping with known disastrous effects. Last but not least, electronic switches offer a much lower inherent transient resistance in comparison to mechanical switches.

The electronic switches DSP40 and SPS20 are operated with the aid of a magnetic switch which can be fixed to the fuselage or elsewhere. By application of a special magnet as shown in the figure in chapter 2, the system becomes switched on or off.

The switches DSP40 and SPS20 are admittedly intended for the purpose of switching supply voltages of receivers and servos, but they may be as well successfully used for other DC switching tasks.

## 2. Wiring of the electronic switch

Connect the voltage source which has to be prospectively switched by two cables with cross sections of 1mm<sup>2</sup> to the DSP40. These cables are customarily contained in the scope of delivery without connectors. The output voltage for the receiver and servos is available at two cables with cross sections of 1mm<sup>2</sup>. The output of the SPS20 consists of two two-wire cables with cross sections of 0,5mm<sup>2</sup> each and two JR connectors. The DPS40 offers the possibility of interconnection of the two inputs and outputs **with galvanic common negative poles**. The SPS20 offers one input and one output only. The electronic switches are connected to the magnetic switch by a triple core cable.

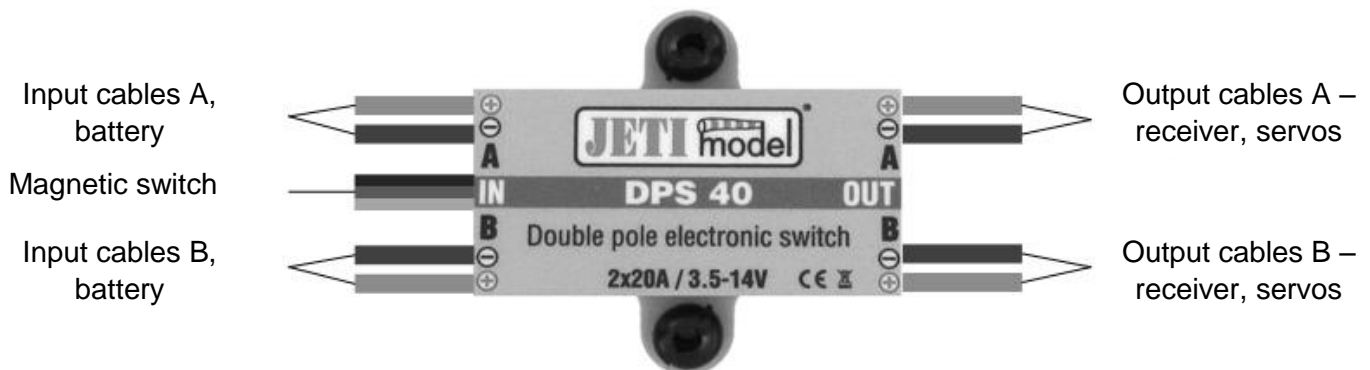

Please take care when connecting the input and output cables, the red cables always represent plus poles and black cables minus poles – their correct connection to plus and minus poles is of utmost importance.

**PAY ATTENTION to correct connection of the input IN and of the output OUT!! In case of reversed connection the switch may be irreversibly destroyed!! It is allowed to connect to the input IN solely batteries, to the output OUT solely receivers, servos etc.**

The magnetic switch is used for switching purposes of the electronic switches DPS40/SPS20. In order to switch on the DPS40/SPS20, the magnet with its cover, as contained in the scope of delivery, must be applied to the application mark in such a manner, that the key mark on the cover and the key mark at the magnetic switch will show the same orientation. The magnetic switch contains a LED showing the „switched on“ state.

- LED on**
- flashing of the LED indicates close range of the magnet
  - permanent light of the LED shows the condition „switched on“

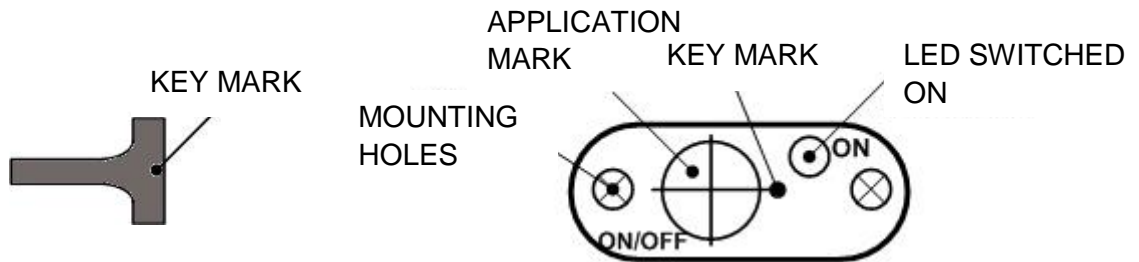

When applying the magnet to the key mark the green LED lights on permanently after a time lag of approximately 1 s and the electronic switch becomes switched on. Switching off takes place analogically, after renewed application of the magnet and another time lag of 1 s the green LED goes out and the system is switched off.

The switching system always keeps the last information whether it has been switched on or off. If you switch on the system with the aid of the magnetic switch and disconnect afterwards the supply battery from the electronic switch, after reconnection of the battery the electronic switch will automatically switch on again. **To be on the safe side you should before disconnection of the supply battery always first switch off the system with the aid of the magnetic switch.**

**Before switching on the electronic switch you should always connect the batteries first and only afterwards switch on the system with the aid of the magnetic switch. Keep this rule also for the switching off procedure. Switch off the system with the aid of the magnetic switch first and disconnect the batteries only afterwards.**

## 2.1 Wiring of the SPS20

Both outputs have a common current supply, i. e. a common plus and minus pole:

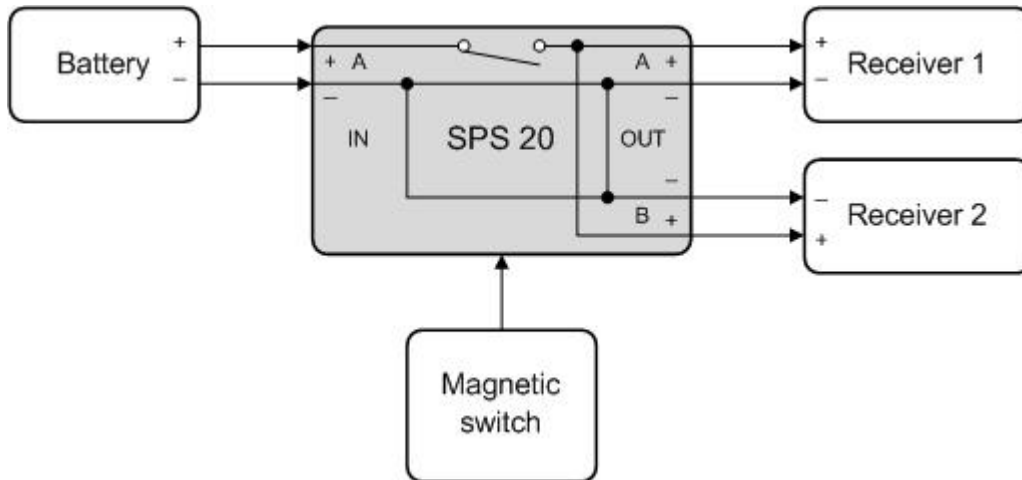

The output current is branched out to two output cable pairs, each pair is able to hold a maximum output transient current of 5A.

## 2.1 The DPS40 wired as two pole switch

The electronic switch DPS40 is able to switch 2 inputs with different voltage potentials:

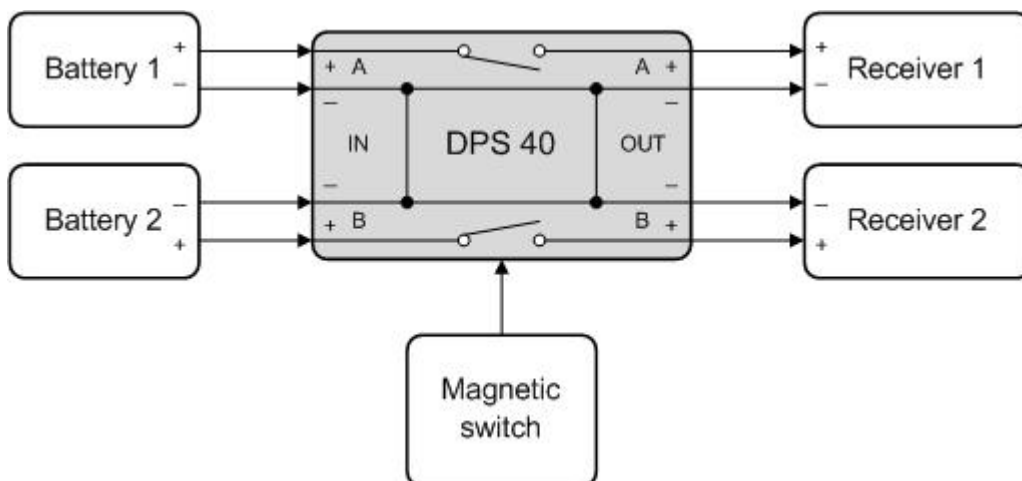

**If 2 Batteries are used, „+ poles“ batteries mustn't be connected with each other!**

## 2.2 The DPS40 switched as single pole switch

By connection of two inputs A, B and two outputs A B of the electronic switch DPS40, current loads of up to 1x40A can be achieved. The cross section of the supply cables at the point of double current must be capable to hold the increased current load:

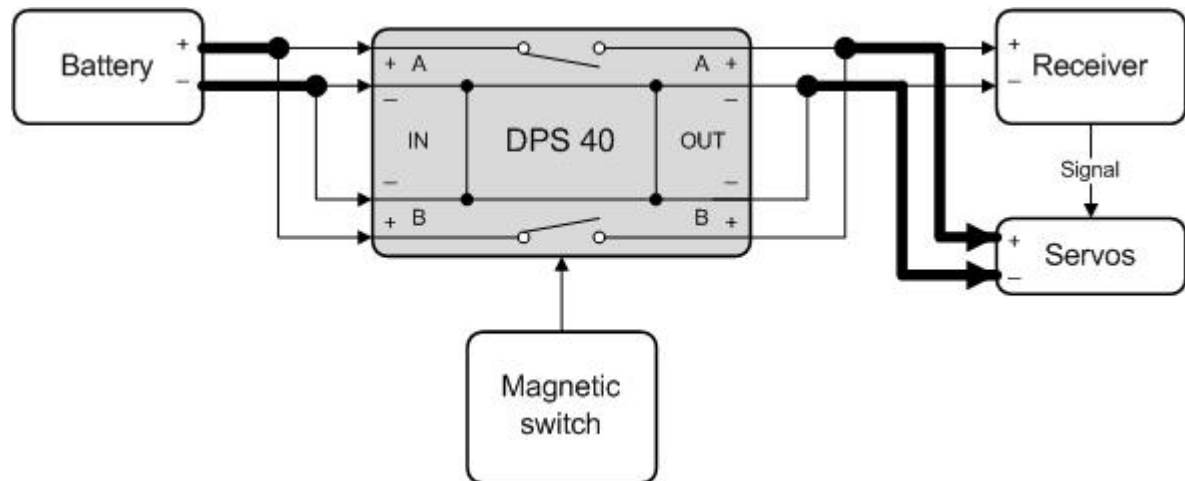

### 2.3 Charging of the battery

The battery can be charged with connected electronic switch (in switched off state – the green LED is off), but it is not allowed to disconnect the battery. The charging voltage is connected directly to the battery (alternatively to the switch input), but by no means to the switch output!! If it becomes necessary to disconnect the battery, disconnect the charging voltage first! In case of nonobservance of these basic rules the electronic switch may be destroyed!

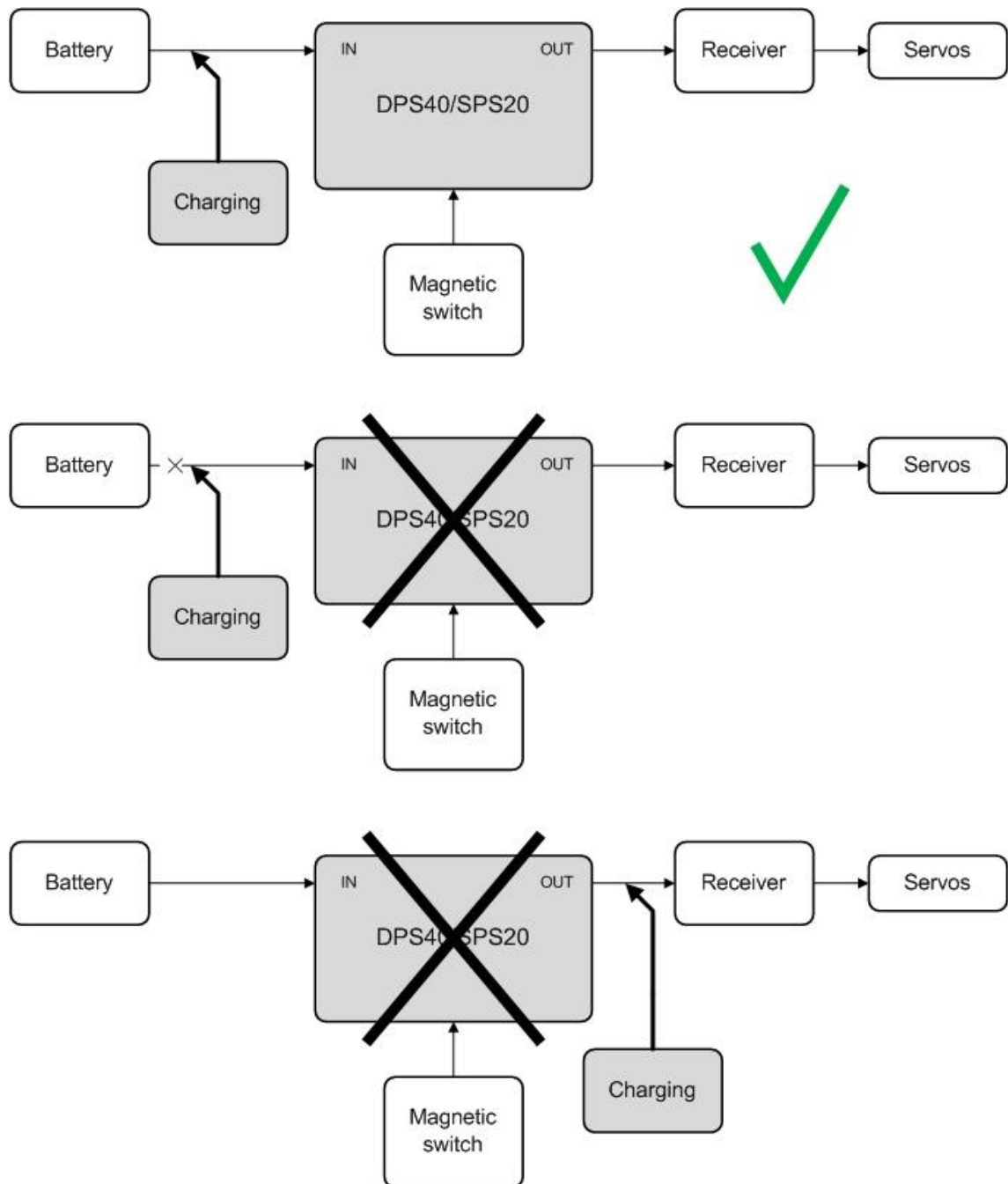

### 3. Installation

The switches DPS40 and SPS20 along with the magnetic switches can be installed in models by taking advantage of the provided mounting holes. When drilling the holes for the magnetic switch apply the upper cover of the magnetic switch as template. The upper cover of the magnetic switch is provided to be fixed to the outside of the fuselage and is mechanically connected to the base with screws. The switches DPS40 and SPS20 can be fixed in the model with the aid of the provided mounting holes and rubber grommets, this way vibration transfer will be minimized.

### 4. Safety basics for handling magnets

Due to the fact that electronic switches are put into operation by means of magnets, it is inevitable to keep certain safety measures when manipulating with magnets. The magnet is fixed within an aluminum holder.

1. Keep a safe distance of all instruments which could be damaged by the influence of a magnet, like for instance TV-sets, credit cards, computers a.s.o. A magnet can disturb the function of a cardiac pacemaker!
2. Keep the magnet away of children, it could be swallowed or cause serious injuries!

### 5. Technical Data of Electronic Switches

Technical Data:	DPS 40	SPS 20
Recommended input voltage	3.5 – 14 V	3.5 – 14 V
Maximum output voltage	16 V	16 V
Current consumption in switched off condition	160 uA	160 uA
Output current pulses	2x 20 A or 1x 40 A	20 A
Transient output current	2x 10 A or 1x 20 A	10 A
Operating temperature	- 20°C till +85°C	- 20°C till +85°C
Weight including cables	31 g	27 g
Dimensions of the module	46 x 45 x 6.5 mm	46 x 45 x 6.5 mm
Dimensions of the magnetic switch	30 x 21 x 5 mm	30 x 21 x 5 mm

### 6. Warranty

For the product we grant a warranty of 24 months from the day of purchase under the assumption, that it has been operated in conformity with these instructions at recommended voltages and that it has not been damaged mechanically. Warranty and post warranty service is provided by the manufacturer.

We wish you successful flying with the products of: **JETI model s.r.o. Příbor**, [www.jetimodel.cz](http://www.jetimodel.cz)